

Automatic Preparers **Polymaker - LM3**

Up to
5000 l/h

Absence of
corrosion

Ultrasonic
level

Instant
flow

PLC

Selection
of
concentration

Colberge Polymaker - LM3

Colberge developed Polymaker - LM3 series, a continuous preparation systems of emulsion polyelectrolyte, fully automatic, allowing to obtain a final product of high quality. The range extends up to 5000 l/h, in concentrations from 1 to 5 g/l.

The Polymaker-LM3 systems include, from series, a large number of accessories and control functions for monitoring the complete process.

The PLC with graphic display, installed in control panel, allows the operator visualize in continuous, the autonomy of the prepared polymer, the water flow, the concentration of selected solution, the functioning state and the active alarms.

The LM3 is constituted by a tank with three chambers (A) - storage, (B) - maturation, (C) - dosing, built in high density polyethylene (very resistant to aggressive environments).

Process description

The ultrasonic level probe (2) (without contact with the liquid), installed in the last chamber in an acrylic holder (3), controls the water intake by a solenoid valve (6) in maturation chamber when the minimum level is reached, and stops at the maximal level. It also allows the activation of a maximum and minimum level alarm, with information on the PLC display, luminous signal and respective external contact with the power supply board.

The flowmeter (7) the piston pressure reducing valve (5) and shut off valve (4) allow to regulate the entry of water continuously, ensuring a dilution flow appropriate to the proper functioning of the preparer within established parameters.

The Y filter (11) allows filtering the impurities at the entrance of the water line so that this work in perfect conditions of use, without any obstruction of the same.

The polyelectrolyte in emulsion is dosed proportionally and simultaneously with water entrance passing by through a static mixer (9) in order to ensure greater homogeneity of the solution when it enters in maturation chamber.

Depending on the selected concentration by direct adjustment in the control panel, and the instantaneous water flow, the dosing pump (8) will vary the frequency of dosing to obtain the desired solution concentration, taking into account the last calibration performed.

The low speed mixer (10) with stainless steel shaft and propeller, installed in the maturation chamber, gives a total homogeneity to the final solution.

Optionally could be installed a second mixer in the dosing chamber.

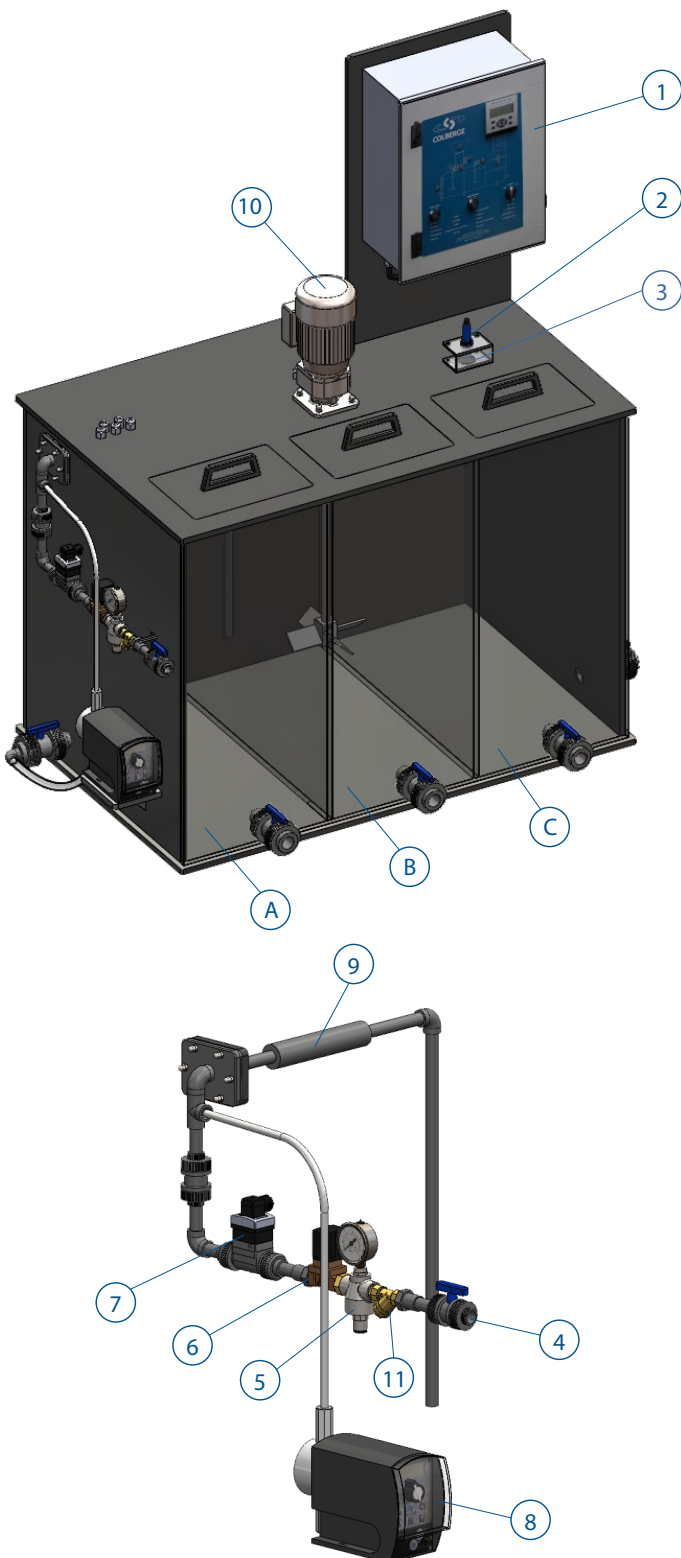



Process control panel of the preparer

Control Panel and synoptic

The control panel (1) provides general security buttons and individual operation switches with beacon and process control panel, with functioning indicator LED of the several elements, allowing the operator the total control of the unit.

Buttons

- Dosing pump - manual, off, automatic;
- Maturation mixer - on / off.

Alarms

The available alarms are detected visually in the led synoptic, as well in the graphic console, associated to a available explanation in the alarms list and a state change of contacts available in the terminal ruler NO/NC.

Active alarms - Stop working

- Flow of water very low or too high;
- Level too high or too low.

Passive Alarms - The unit continues to work

- Storage level;
- Thermal of dilution mixer;
- Thermal of dosing pump.

Options

- 3° mixer;
- Overflow;
- Hydraulic and electric assembly of the dosing pump;
- Assembly in mirror.

Views / Dimensions

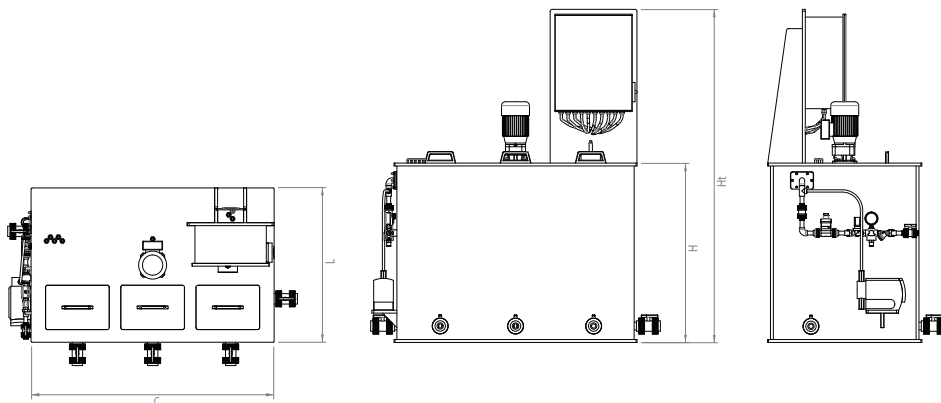

Polymaker LM3	Model	Total Dimensions				Volume (L) Geometric	Maximum Capacity (l/h)		Mixer	
		Ht (mm)	H (mm)	L (mm)	C (mm)		15 min	30 min	Power (kW)	Ø mm
	LM3-16	1700	900	850	1300	400	1600	800	0,25	200
	LM3-24	1800	1000	950	1550	600	2400	1200	0,25	200
	LM3-36	1800	1000	1050	2050	900	3600	1800	0,37	350
	LM3-50	1900	1100	1200	2300	1250	5000	2500	0,55	350